

# DATASHEET



## 2025 IR LED ILLUMINATOR

**MODEL: DM/2025-700**

Dedicated Micros has launched a powerful, robust infra-red LED illuminator that offers an economical, low maintenance and environmentally-friendly alternative to white flood lighting.

The 2025 IR LED Illuminator provides discrete illumination for cameras such as the SDH36 PTZ Outdoor Speed dome that have spectral responses extending into the infra-red range. It can give comprehensive coverage for large areas, reaching up to 525 feet from the source at the nominal beam width of 30 degrees. The maximum beam width is 70 degrees at close range, and four power settings ensure that the effective distance of the illuminator can be tailored to individual site conditions.

The rugged design features a high impact, polycarbonate front sheet to withstand attack by vandals. The LEDs have a typical life expectancy in excess of five years, eliminating the regular maintenance required of halogen-based illuminators, and the unit comes with lightning protection as standard. The 2025 IR LED Illuminator is also water and dust resistant to IP66.

For ease of installation the IR LED Illuminator is supplied with a two-axis wall mounting bracket, supporting easy horizontal and vertical adjustment.

## FEATURES

- Typical LED life in excess of 5 years
- 2 axis wall mounting bracket (included)
- Illumination to 525 feet
- Wide angle of view to 70 degrees at close range
- Low power consumption
- 4 power settings
- Vandal resistant
- LED wavelength 850nm – faint glow visible
- Environmental protection to IP66
- Reduced running costs compared with halogen bulbs
- Resistance to lightning strikes
- Adjustable horizontal & vertical positioning
- Compatible with existing 2000 series pan/tilt heads (except continuous rotation version)
- Automatic switching via photocell
- Additional switch inputs for remote on/off control



# SPECIFICATION

## LED WAVELENGTH

850nm

## BEAM WIDTH

30 degrees nominal

## PHOTOCELL

Sensitive to 25 Lux

## POWER INPUT

90 - 264 VAC, 47 - 63Hz

## CURRENT DRAW

2A Max

## WEIGHT

15.4 lbs (7kg) (Illuminator)

2 lbs (1kg) (Wall bracket)

11 lbs (5kg) (PSU/Control)

## ENVIRONMENTAL PROTECTION

Level IP66 (not water resistant)

## OPERATING TEMPERATURE

-4° to 122° F (-20°C to +50°C)

## FINISH

Powder coated and stoved

Ash Grey, leatherette finish to BS4800 00-A-01

## All Dimensions in millimeters

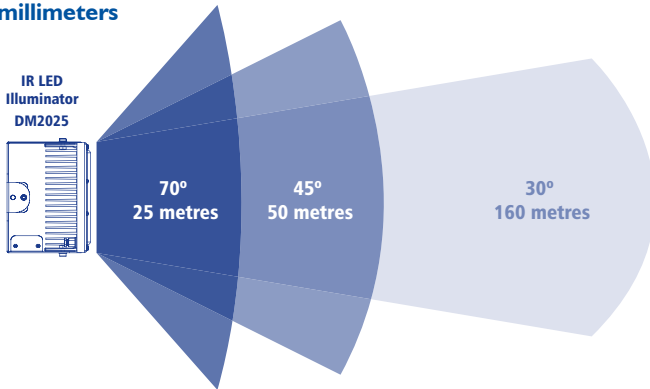

Illumination/distance achievable when used with a  
Dedicated Micros SDH36 PTZ Speed Dome

PLEASE CHECK THE WEBSITE FOR DETAILS OF  
COMPATIBLE PRODUCTS AND OTHER LATEST  
DEVELOPMENTS

## PRODUCT CODES

DM/2025-700 LED IR Illuminator, 850nm, 30 degree (includes PSU/control unit)

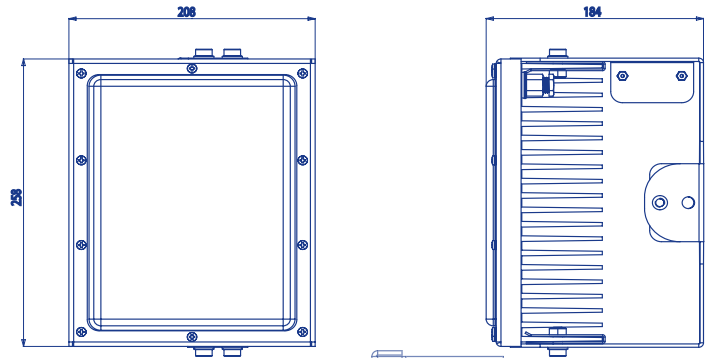

90° Vertical

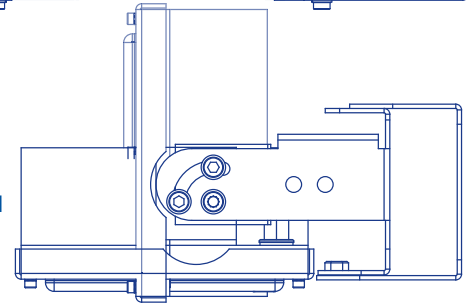

20° Left to Right

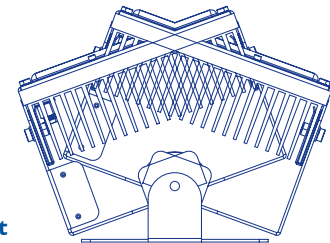

2 axis bracket

PLEASE CHECK THE WEBSITE OR YOUR LOCAL REPRESENTATIVE FOR PRODUCT ORDERING INFORMATION AND OTHER DEVELOPMENTS

[www.dedicatedmicrosinc.com](http://www.dedicatedmicrosinc.com)

Dedicated Micros USA

14434 Albemarle Point Place, Suite 100, Chantilly, Virginia 20151 USA Toll Free : 800 864-7539 Tel: +1 703 904-7738 Fax: +1 703 904-7743

Dedicated Micros Canada

5580 Explorer Drive, Suite 501, Mississauga, Ontario L4W 4Y1 Tel: +1 905 602-6222 Fax: +1 905 602-6221

The manufacturer reserves the right to change the specification without notice. All trademarks are courtesy of registered owners.

The DM logo is a trademark of Dedicated Microcomputers Group Ltd. NetVu Connected is a trademark of the AD group.



© Copyright Dedicated Micros, Inc.

MKT-2025-D-002E